

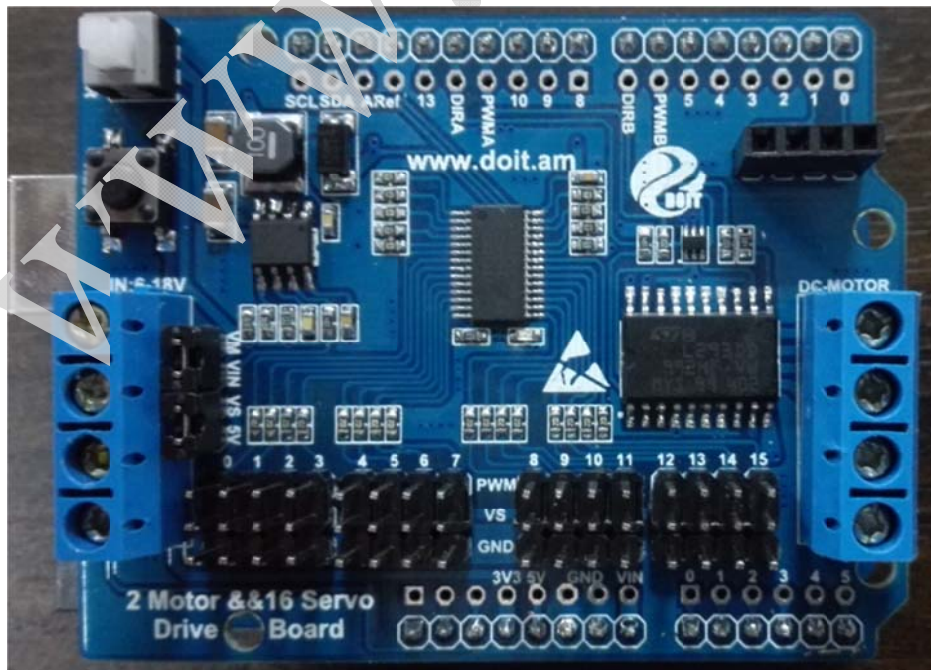

Doctors of Intelligence & Technology (DOIT)

User Manual for 2-way Motor & 16-way Servos Shield



25 April 2016



Catalogue

Introduction	错误!未定义书签。
1. Download the Arduino software.....	错误!未定义书签。
2. Test Arduino IDE	错误!未定义书签。
3. Other ways	错误!未定义书签。
4. Support and Service	错误!未定义书签。

www.doit.am



1. Introduction

2-way Motor & 16-way Servo Drive Shield is a compatible with Arduino UNO R3 and ESPduino development board. This module can be inserted directly into the Arduino UNO and/or ESPduino. But if using ESPduino, you can develop quickly and conveniently a tank/car chassis controlled by WiFi. More details, please see the following link: <http://www.smartarduino.com/view.php?id=94895>.

This driver shield can control **2-way DC motor (4.5~18v) and 16-way servo (5~18V)**, which is very suitable for the control of mobile robot with robotic arm. This board is designed by using L293DD, which can drive directly 2-way DC motor or 1-way stepping motor. Its max current can be **1.2A**.

16-way servo is controlled by IIC interface on the board.

The IO interfaces is used as the control interface for Arduino UNO and ESPduino. Thus, just the four ports **D6, D7, D11, and D12** (as for ESPduino, it is **D12, D13, D3, D1**) is defined as **PWMB (speed for motor B), DIRB (the turn direction for motor B) PWMA(speed for motor A), and DIRA(the turn direction for motor B)**. The humanized design is used the power switch, which can make one on/off the power conveniently.

The board can directly be used to control the intelligent robot by Bluetooth (pre-server) and/or WiFi. More details, please visit:

<http://www.doit.am>; www.smartarduino.com.

2. Specifications

- POWER:
 - Power for motor(V_M): 4.5V~36V, can power separately;
 - Power for servo(V_{IN}): 5~18V, can power separately;
 - How to use power connection:

If short V_M and V_{IN}, only can control the motor with 6-18V;

If short V_S and V_{IN}, only can control the servo with 6-18V;

If short VM and VIN, and short VS and 5V, then CAN control the 2-way motor (with 6-18V) and 16-way 5V servo.

- Working Current I_o : $\leq 1.2A$;
- Max power consumption: $4W$ ($T=90^{\circ}C$) ;
- Input for control signal: High level: $2.3V \leq V_{IH} \leq VIN$; low level: $-0.3V \leq V_{IL} \leq 1.5V$
- Working temperature: $-25^{\circ}C \sim +125^{\circ}C$;
- Driven mode: double big power H bridge driver;
- Weight: about 46g

3. Size

PCB view is shown in Figure 1, and Figure 2 is the real product. To get it, from the following: <http://www.smartarduino.com/view.php?id=94895>

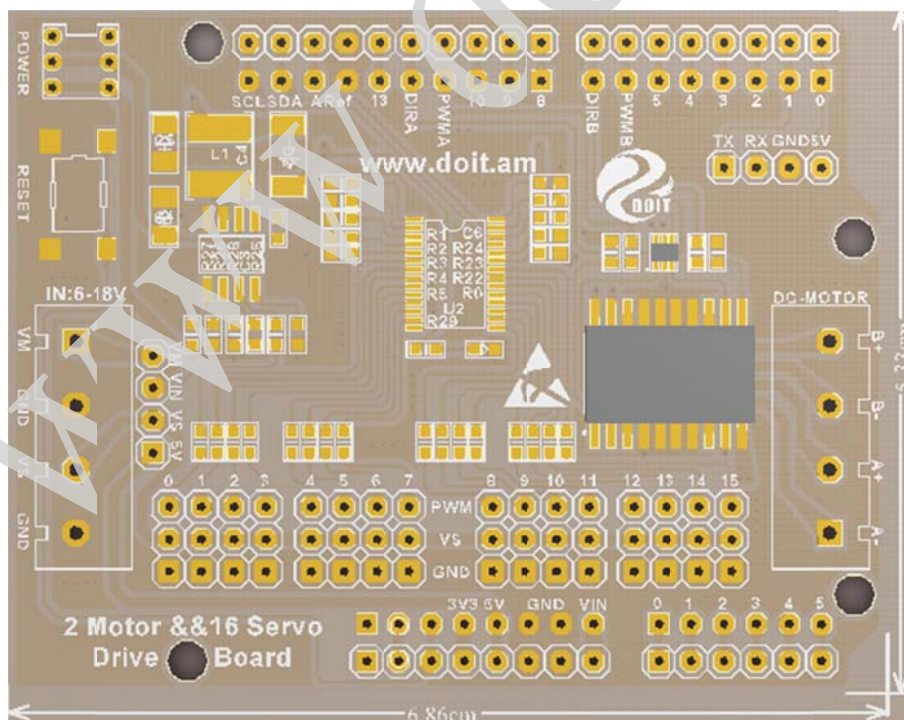

Figure 1 PCB view for 2Motor & 16 Servo Drive Board

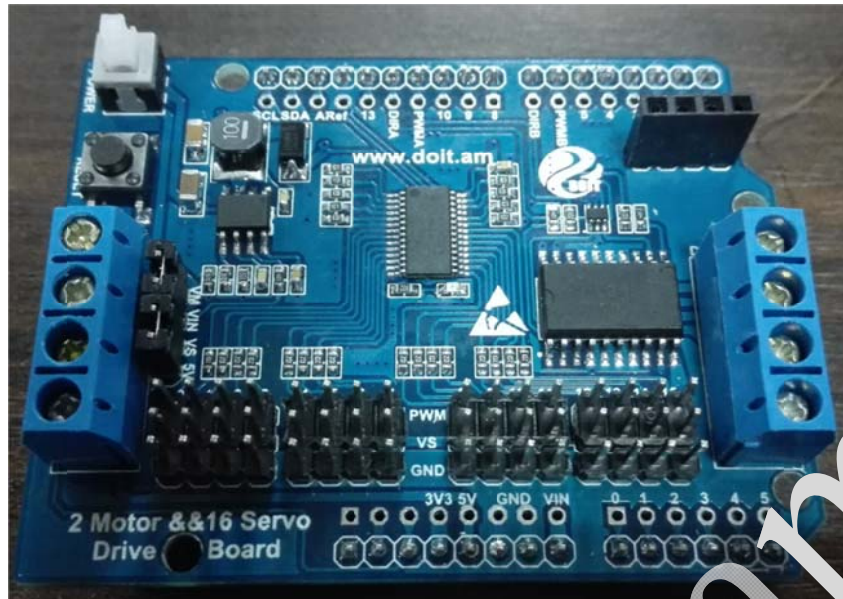

Figure 2 Real product for 2Motor & 16 Servo Drive Board

4. Interface for the Shield Board

Table 1 provides the definitions of the pins, which are also printed on the board.

Table 1 Definition for each pin

Item	Name	Function	Input/output	Notation
servo	PWM	Input for servo	input	-
	VS	Power for servo	input	-
	GND	Grand for servo	-	-
	0-15	Code for servo	-	0-15 denote the 16 servo
	SCL	Control for servo	-	IIC interface, address:0X40
	SDA	Control for servo	-	IIC, address: 0X40
motor	A	A+,A-	output	A+, A- for the motor A
	B	B+,B-	output	B+, B- for the motor B
	DIRA	output	-	Direction control for motor A
	PWMA	output	-	Speed control for motor A
	DIRB	output	-	Direction control for motor B
	PWMB	output	-	Speed control for motor B
power	VM	Power for motor	-	4.5V-36V, see the specification
	VS	Power for servo	-	6-18V, see the specification
	POWER	switch	-	Control the power
	RESET	reset	-	Connect the board

other	6P, 8P, 8P, 10P can be used to test; TX, RX, GND, 5V can be inserted Bluetooth module
-------	-------------------------------------------------------------------------------------------------

After insert into the Arduino UNO R3, to get it from the following:

<http://www.smartarduino.com/view.php?id=94896>

more applications can be visit the following.

http://www.smartarduino.com/doarm-s7-robot-arm-t900-controlled-by-espduino-wifi_p95024.html

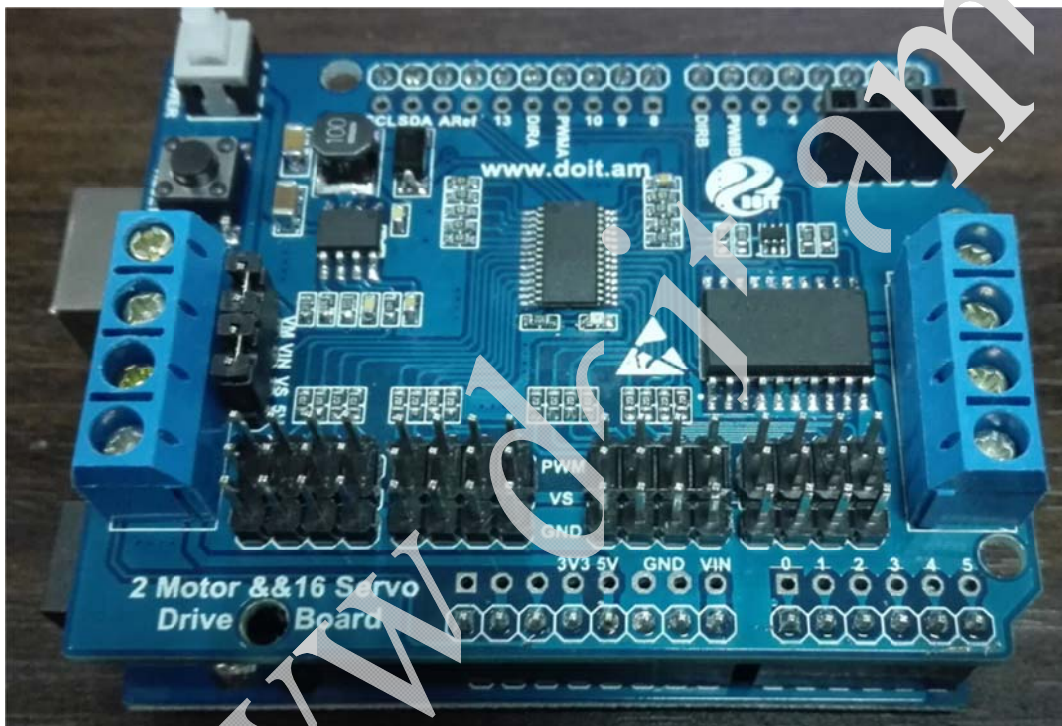

Figure 3 After inserted into the Arduino UNO R3

5. Revised Record

Table2 revised history

Version	scope	date
1.00	DrAlt Version	2015-12-02



6. Support and Service

When you get the board, you can visit the following website to get the more details. Our professional sites:

<http://bbs.smartarduino.com/>

www.doit.am

Skype: yichone

Email: yichoneyi@163.com

WhatsApp: +8618676662425

www.doit.am